

## 3M-Matic™ Side Belt Adjustable Case Sealer 800a/800a3 Versatile Side Belt Drive

### UP TO 40 CASES PER MINUTE

Located on each side of the 3M-Matic™ Automatic Adjustable Case Sealer 800a, traction-grip drive belts center and stabilize a variety of RCS heights. The side drives are even repositionable to provide a greater stability for taller boxes. Features include:

- Dual masts and dual crossbars for taping head stability
- Twin gear motor drives for dependability with cases up to 85 pounds (38 kg)
- Easy height and width adjustments for a wide range of RSC sizes.
- Top flap compression rollers to close flaps for an improved seal
- Centrally-located emergency stop for quick and easy access
- Designed for use with 36-48mm (1.5"-2") Scotch® Box Sealing Tapes; model 800a3 is available for use with 72mm (3") tape

3M-Matic™ Adjustable Case Sealer 800ab is available for sealing bottom flaps only.

**Options:** Locking casters, infeed and exit conveyors, low tape indicator, box hold down attachment

3M™ AccuGlide™ 3 Taping Head for low impact sealing and higher productivity



Shown with optional accessories

### BOX CAPACITY INCHES (MM)

Machine	Length	Width	Height	Height Range w/masts raised	Weight Range Lbs. (kg)
800a	Min: 6 (150) Max: Unlimited	Min: 6 (150) Max: 21.5 (546)	Min: 4.75 (120) Max: 24.5 (625)	Min: 8.0 (203) Max: 28.5 (725)	Min: 5 (2.3) Max: 85 (38)
800a3	Min: 6 (150) Max: Unlimited	Min: 7 (175) Max: 21.5 (546)	Min: 4.75 (120) Max: 24.5 (625)	Min: 8.0 (203) Max: 28.5 (725)	Min: 5 (2.3) Max: 85 (38)

Contact your 3M Certified Specialist for special modifications that may be available for sizes not listed

**Note:** The 3M-Matic™ Adjustable Case Sealer 800a/800a3 can accommodate most boxes within the size range listed here.

However, if the Box Length in Direction of Seal divided by Box Height is less than .75 in boxes should be test run to ensure proper machine performance.

## SPECIFICATIONS

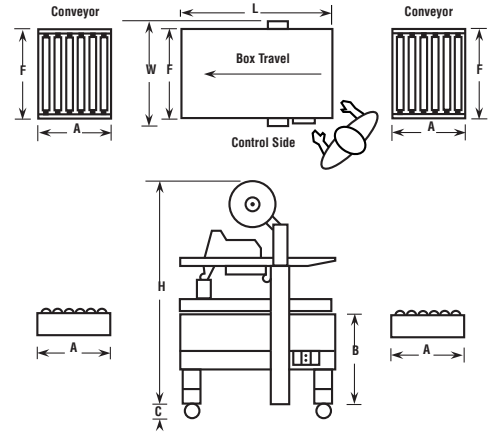

3M-Matic™ Case Sealer 800a

3M-Matic™ Case Sealer 800a3

800a & 800a3 Footprint

## MACHINE DIMENSIONS INCHES (MM)

Machine	Tape Size In. (mm)	Machine Weight* Lbs. (kg)	W	T	H	A*	B	C***	F	Electrical	Operating Rate	Drive Belt Speed
800a	1.5-2 (36-48)	350 (160)	38.5 (978)	36 (914)	Min: 53 (1346) Max: 86 (2184)	18 (457)	Min: 24 (610) Max: 35 (889)	4 (102)	24.5 (622)	115V 60Hz 2.8A 315 watts 8' cord	Up to 40 per minute	100 fpm (.05 m/s)
800a3	2-3 (48-72)											
800ab	3 (72)											
800ab3												

\* Uncrated \*\* Optional infeed/exit conveyors v\*\*\* Optional casters

Use with clean dry boxes in dry, relatively clean environments at 40°F to 120°F (4.4°C to 48.9°C).

Contact your 3M Certified Specialists for special modifications that may be available for sizes not listed.

Note: This technical information and data should be considered representative or typical only and should not be used for specification purposes.

**3M** Premier Service  
Industrial Products Distributor