

3M-Matic™ Side Belt Adjustable Case Sealer 800asb Small Box Productivity

UP TO 24 LOW AND NARROW CASES PER MINUTE

Located on each side of the 3M-Matic™ Side Belt Adjustable Case Sealer 800asb traction-grip drive belts center and stabilize low and narrow boxes for consistently accurate taping. Designed specifically to handle small boxes to regain productivity in your operation.

Features include:

- Dual masts with twin lead screws for taping head stability and uniform height adjustment
- Twin gear motor drives for shift after shift dependability with cases up to 85 pounds (38 kg)
- Convenient height and width adjustments for a range of RSCs
- Centrally-located emergency stop for quick and easy access
- Designed for use with 36mm (1.5") Scotch® Box Sealing Tape

Options: Lockable casters for easy movement, infeed platform attachment, exit conveyor, box hold down attachment

3M™ AccuGlide™ Taping Head II for low impact sealing that protects cases



Shown with optional accessories

BOX CAPACITY INCHES (MM)

Machine	Length	Width	Height	Weight Range Lbs. (kg)
800asb	Min: 6 (150) Max: Unlimited	Min: 3.9 (99) Max: 21.5 (546)	Min: 2.75 (70) Max: 22.8 (568)	Min: 5 (2.3) Max: 85 (38)

Contact your 3M Certified Specialist for special modifications that may be available for sizes not listed
 Note: The 3M-Matic™ Adjustable Case Sealer 800asb can accommodate most boxes within the size range listed here.
 However, if the Box Length in Direction of Seal divided by Box Height is less than .75 in boxes should be test run to ensure proper machine performance.

SPECIFICATIONS

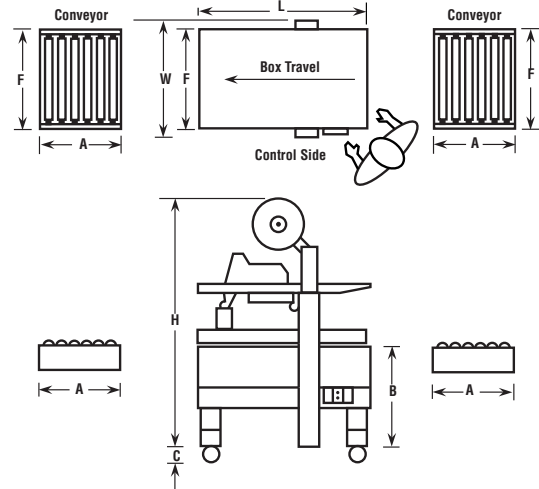

3M-Matic™ Side Belt Adjustable Case Sealer 800asb

800asb Footprint

MACHINE DIMENSIONS INCHES (MM)

Machine	Tape Size In. (mm)	Machine Weight* Lbs. (kg)	W	L	H	A**	B	C***	F	Electrical	Operating Rate	Drive Belt Speed
800asb	1.5 (36)	335 (152)	38.5 (978)	36 (914)	Min: 53 (1346) Max: 86 (2184)	18 (457)	Min: 24 (610) Max: 35 (889)	4 (102)	24.5 (622)	115V 60Hz 3.8A 440 watts 8' cord	Up to 24 per minute	57 fpm (.3 m/s)

* Uncrated ** Optional infeed/exit conveyors *** Optional casters

Use with clean dry boxes in dry, relatively clean environments at 40°F to 120°F (4.4°C to 48.9°C).

Contact your 3M Certified Specialists for special modifications that may be available for sizes not listed.

Note: This technical information and data should be considered representative or typical only and should not be used for specification purposes.

