

2-EZ[®] XL Series Case Erector For Large Cases

Combi Packaging System's heavy duty side belt drive case erectors form and bottom seal large and extra large cases at speeds up to 10 cases per minute. These machines are built for optimal durability, reliability and value. Engineered with the industry's strongest frame (lifetime warranty) for the most demanding 3-shift environments, the 2-EZ[®]XL, 2-EZ[®]XL HS, and 2-EZ[®]XXL can readily integrate into your existing line. Combi's user-friendly EZ-load walk-in case magazines and 2-minute changeover system are standard features. The redesigned 2-EZ[®]XL series case erectors will provide years of dependable service and can form and seal the widest variety of large cases, from single wall to triple wall corrugated.

STANDARD FEATURES

- Large case capabilities up to 10 cases per minute
- EZ Load Walk-In 50" Powered Case Magazine
- Heavy-duty Welded Steel Construction with Epoxy "Steel It" Paint
- 3M Accuglide™ Tapeheads
- Allen-Bradley components
- Dual Belt Driven (2-EZ[®]XL and 2-EZ[®]-XXL) or Servo Driven (2-EZ[®]XL HS) Carriage Assembly
- Self-Cleaning Vacuum System with Air Purge
- Safety Back Up Photo Eye with 20' Cord and Mounting Bracket
- Right Hand or Left Hand Execution



DESIGNED TO PERFORM:

The flat case blank stands vertically in the easy to load, walk-in case magazine. The case blank is extracted from the magazine with vacuum cups and formed by a retracting squaring arm. The rear minor flap is rotated 90°. The case is then transferred into the dual belt drives where it is transported across the tape head and is bottom sealed with a strip of pressure sensitive tape.

OPTIONS:

- Hot Melt Glue closure
- Heavy Duty Locking Casters
- Low Case Supply Alarm
- Low Tape/No Tape Alarm Kit
- 3 and 6" Wide 3M Accuglide™ Tape Heads (model and speed dependent)
- Spare Parts Kit
- Cluster Lubrication Kit
- Stainless Steel Framework
- NEMA 4 Water Wash Down
- External Filter for Vacuum Pump
- Extended Warranty

ELECTRICAL REQUIREMENTS:

- 115 volt/1ph/20A
- 240 volt/3ph/20A

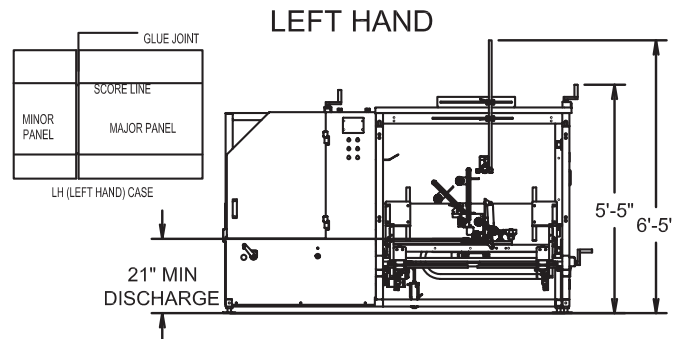
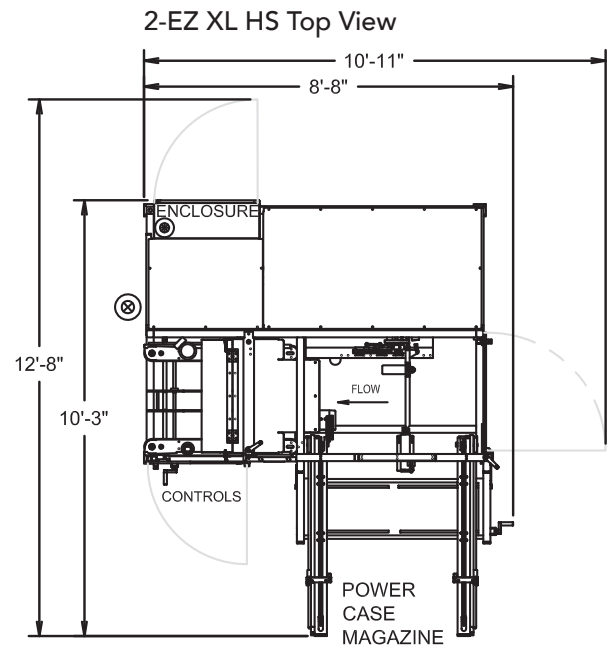

SPECIFICATIONS(MM)

Model	Case Size Min* (LxWxH)	Case Size Max (LxWxH)	Speed: CPM*	Overall System Footprint
2-EZ [®] XL	13" x 10" x 6" (33x25x15cm)	24" x 20" x 18" (61x51x46cm)	up to 10	8'8" x 8'6" 264x259cm
2-EZ [®] XL HS	13" x 10" x 6" (33x25x15cm)	24" x 20" x 18" (61x51x46cm)	up to 15	8'8" x 10'3" 264x312cm
2-EZ [®] XXL	21" x 15" x 9" (53x38x22cm)	32" x 26" x 30" (81x66x76cm)	up to 8	10'8" x 11'8" 327x356cm
2-EZ [®] XXL HS	21" x 15" x 9" (53x38x22cm)	32" x 26" x 30" (81x66x76cm)	up to 12	10'8" x 11'8" 327x356cm

*Speeds are case size dependent