

## RELIABLE SEMI-AUTOMATIC L-SEALING

Eastey's Value Series Combo Unit offers a L-sealer and shrink tunnel on a common frame for simple setup, perfect alignment and mobility within the plant.

## A PERFECT MATCH

The Value Series Combo Unit combines a rugged EASTEY L-sealer and shrink tunnel on a common frame with one power source. This allows for quick setup, perfect alignment and consistent product sealing. A common base with casters makes this a very portable system for transportation within the plant.

## BUILT RIGHT...PRICED RIGHT

Proven reliable over and over again, these intermediate level EASTEY L-Sealers provide you with all the quality features found in much higher priced machines. They are designed and built to give you all the performance features needed for positive sealing a wide variety of films including polyolefin and PVC.

## RUGGED DESIGN

EASTEY Value Series Combo Unit are expertly welded on 12 gauge steel frames and designed to handle the day to day abuse of manual sealing in most shrink wrap applications. Rugged seal arms and magnet clamping are just some of the features that provide the durability you have come to rely on from EASTEY. See for yourself why EASTEY has been a leader in the shrink packaging industry for over 25 years.

## STANDARD FEATURES

- Designed to seal polyolefin or PVC shrink films
- All-welded main frame from 12 gauge steel
- Seal head equipped with gas shock head return
- Dual locking magnet clamps apply consistent pressure across seal bar
- Automatic cycle timing with adjustable dwell time
- Solid state temperature control adjustable for a variety of films
- Wide product tray provides large work area
- Seal head can be raised or lowered to center-seal product
- Film rack positioned beneath product tray for simple film loading
- Adjustable pin perforator provides air evacuation
- Positive shrinking of all products assured with consistent air flow
- 15" wide x 8" tall x 26" long chamber
- Variable speed tunnel conveyor and variable air flow for a variety of shrink applications
- Rugged stainless steel mesh belt conveyor or live roller conveyor on tunnel
- Seal size of 16" x 20"
- Maximum film width up to 18"
- Heavy duty casters for transportation within plant
- Easy to use design requires minimal training and maintenance



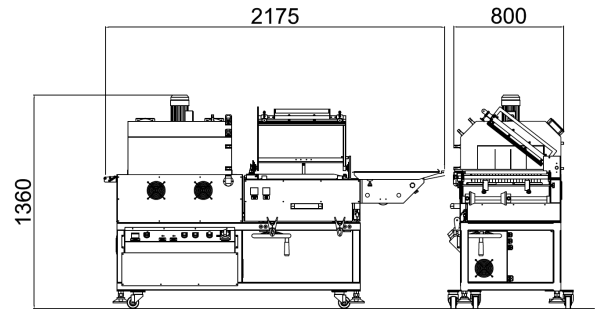

## FEATURES:

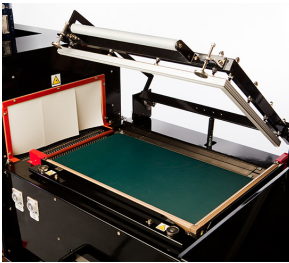

### Takeaway Conveyor

Seal head can be raised or lowered to center the seal on your product

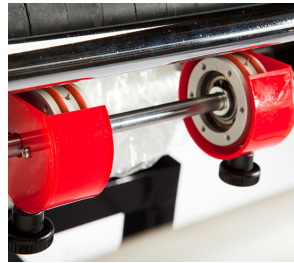

### Pin Perforator

Adjustable pin perforator provides air evacuation in film which allows for proper film shrinkage



### Control Panel

Easy to use control panel lets users adjust temperature settings for their specific application



### Inside of Tunnel

Consistent air flow provides positive shrinking of polyolefin or PVC shrink films

MODEL NUMBER	MACHINE DIMENSIONS			CONVEYOR DIMENSIONS			CONVEYOR WIDTH	CONVEYOR LENGTH	STANDARD POWER			Weight	Shp. Wt.
	Width	Height	Length	Width	Height	Length			Volts	Amps	Phase		
VS1620	32"	53.25"	86.5"	15"	8"	26"	13.5"	13.5"	220	30	1	650 lbs	750 lbs
	81 cm	134 cm	218 cm	38 cm	20 cm	66 cm	34 cm	34 cm				294 kg	340 kg